

Discovery Room



COLOR ME!



GEORGE EASTMAN, AS AN AMATEUR, RIGGED UP HIS FIRST PORTABLE PHOTOGRAPHIC OUTFIT WHILE WORKING IN A BANK IN ROCHESTER, N.Y.

Discovery Room



COLOR ME!

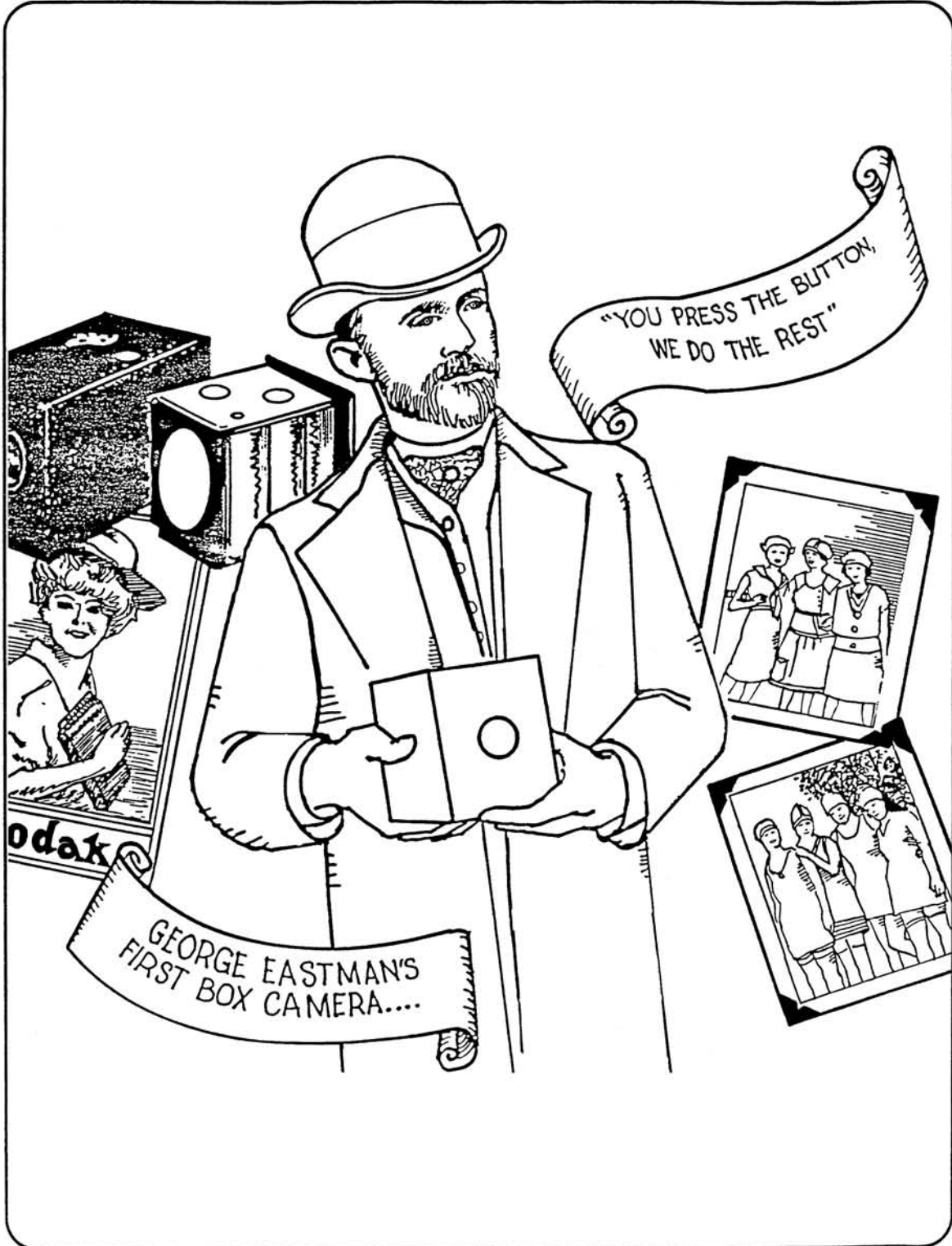

Discovery Room



COLOR ME!



This is the KODAK, the camera
Mr. Eastman's company
sold in 1888.

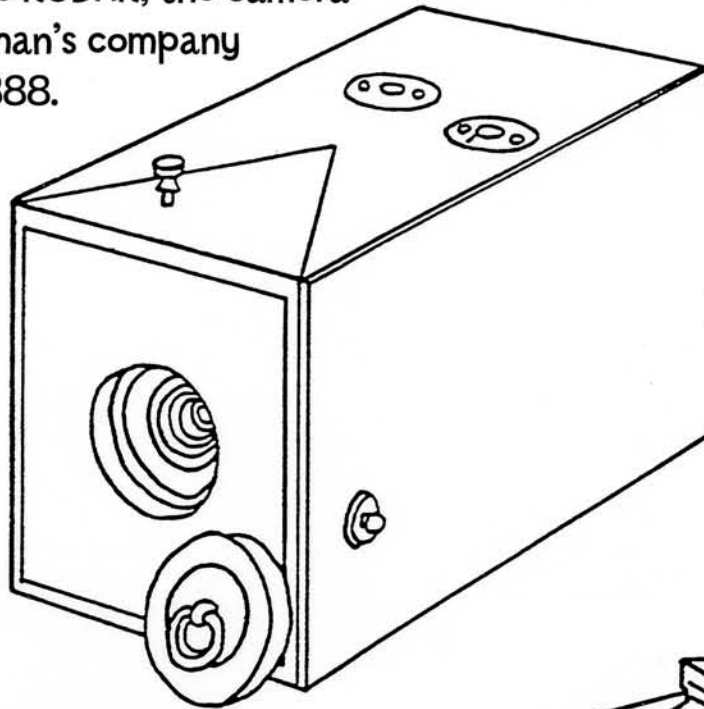

The key was used
to wind the film.

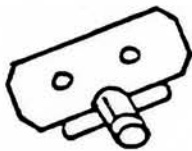

Film was loaded onto
this roll holder which fit
into the camera. 100 pictures
could be taken on one roll of film.

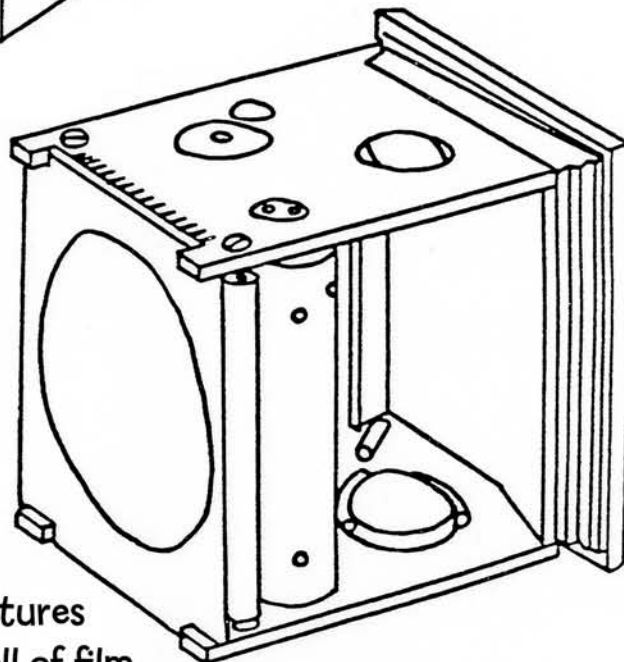

Discovery Room



COLOR ME!



“You Press the Button, We Do the Rest”
was the Kodak advertising slogan.





Take a
KODAK
with you



The Kodak Girl